

Government of Pakistan

National Vocational and Technical Training Commission

Prime Minister's Hunarmand Pakistan Program

"Skills for All"



Course Contents/ Lesson Plan

Course Title: Advance CNC Operator

Duration: 6 Months

Course Details / Description & Preliminaries

Course Title	Advance CNC Operator
Objectives and Expectations	<p data-bbox="500 346 1424 441"><u>Employable skills for DAE (Mechanical) through an intensive course on Advanced CNC Operator</u></p> <p data-bbox="500 520 1424 1018">This is a special course designed to address unemployment in the youth. The course aims to achieve the above objective through hands on practical training delivery by a team of dedicated professionals having rich market/work experience. This course is therefore not just for developing a theoretical understanding/back ground of the trainees. Contrary to that it is primarily aimed at equipping the trainees to perform commercially in a market space in independent capacity or as a member of a team.</p> <p data-bbox="500 1045 1424 1423">The course therefore is designed to impart not only technical skills but also soft skills (i.e. interpersonal/communication skills; personal grooming of the trainees etc.) as well as entrepreneurial skills (i.e. marketing skills; free lancing etc.). The course also seeks to inculcate work ethics to foster better citizenship in general and improve the image of Pakistani work force in particular.</p> <p data-bbox="500 1491 792 1528"><u>Main Expectations:</u></p> <p data-bbox="500 1549 1424 1759">In short, the course under reference should be delivered by professional instructors in such a robust hands- on manner that the trainees are comfortably able to employ their skills for earning money (through wage/self-employment) at its conclusion.</p> <p data-bbox="500 1780 1424 1875">This course thus clearly goes beyond the domain of the traditional training practices in vogue and underscores an</p>

Key Features of Training & Special Modules

expectation that a market centric approach will be adopted as the main driving force while delivering it. The instructors should therefore be experienced enough to be able to identify the training needs for the possible market roles available out there. Moreover, they should also know the strengths and weaknesses of each individual trainee to prepare them for such market roles during/after the training.

- i. Specially designed practical tasks to be performed by the trainees have been included in the Annexure-I to this document. The record of all tasks performed individually or in groups must be preserved by the management of the training Institute clearly labeling name, trade, session etc so that these are ready to be physically inspected/verified through monitoring visits from time to time. The weekly distribution of tasks has also been indicated in the weekly lesson plan given in this document.
- ii. In order to materialize the main expectations, a special module on **Job Search & Entrepreneurial Skills** has been included in the later part of this course (5th & 6th month) through which, the trainees will be made aware of the Job search techniques in the local as well as international job markets (Gulf countries). Awareness around the visa process and immigration laws of the most favored labor destination countries also forms a part of this module. Moreover, the trainees would also be encouraged to venture into self-employment and exposed to the main requirements in this regard. It is

also expected that a sense of civic duties/roles and responsibilities will also be inculcated in the trainees to make them responsible citizens of the country.

- iii. A module on **Work Place Ethics** has also been included to highlight the importance of good and positive behavior at work place in the line with the best practices elsewhere in the world. An outline of such qualities has been given in the Appendix to this document. Its importance should be conveyed in a format that is attractive and interesting for the trainees such as through PPT slides +short video documentaries. Needless to say that if the training provider puts his heart and soul into these otherwise non-technical components, the image of Pakistani workforce would undergo a positive transformation in the local as well as international job markets.

In order to maintain interest and motivation of the trainees throughout the course, modern techniques such as:

- motivational lectures
- success stories
- case studies

These techniques would be employed as an additional training tool wherever possible (these are explained in the subsequent section on Training Methodology).

Lastly, evaluation of the competencies acquired by the trainees will be done objectively at various stages of the training and proper record of the same will be maintained. Suffice to say that for such evaluations, practical tasks would be designed by the

**Training Tools/
Methodology**

training providers to gauge the problem solving abilities of the trainees.

(i) Motivational Lectures

The proposed methodology for the training under reference employs motivation as a tool. Hence besides the purely technical content, a trainer is required to include elements of motivation in his/her lecture to inspire the trainees to utilize the training opportunity to the full and strive towards professional excellence. Motivational lectures may also include general topics such as the importance of moral values and civic role & responsibilities as a Pakistani. A motivational lecture should be delivered with enough zeal to produce a deep impact on the trainees. It may comprise of the following:

- Clear Purpose to convey message to trainees effectively.
- Personal Story to quote as an example to follow.
- Trainees fit so that the situation is actionable by trainees and not represent a just idealism.
- Ending Points to persuade the trainees on changing themselves.

A good motivational lecture should help drive creativity, curiosity and spark the desire needed for trainees to want to learn more. Impact of a successful motivational strategy is amongst others commonly visible in increased class participation ratios. It increases the trainees' willingness to be engaged on the practical tasks for longer time without boredom and loss of interest because they can clearly see in their mind's eye where their hard work would take them in short (1-3 years); medium (3 -10 years) and long term (more than 10 years).

As this tool is expected that the training providers would make arrangements for regular well planned motivational lectures as part of a coordinated strategy interspersed throughout the training period as suggested in the weekly lesson plans in this document.

(ii) Success Stories

Another effective way of motivating the trainees is by means of Success Stories. Its inclusion in the weekly lesson plan at regular intervals has been recommended till the end of the training.

A success story may be disseminated orally, through a presentation or by means of a video/documentary of someone that has risen to fortune, acclaim, or brilliant achievement. A success story shows how a person achieved his goal through hard work, dedication and devotion. An inspiring success story contains compelling and significant facts articulated clearly and easily comprehensible words. Moreover, it is helpful if it is assumed that the reader/listener knows nothing of what is being revealed. Optimum impact is created when the story is revealed in the form of:-

- Directly in person (At least 2-3 cases must be arranged by the training institute)
- Through an audio/ videotaped message (2-3 high quality videos must be arranged by the training institute)

It is expected that the training provider would collect relevant high quality success stories for inclusion in the training as suggested in the weekly lesson plan given in this document.

Suggestive structure and sequence of a sample success story and its various shapes can be seen at annexure III.

(iii) Case Studies

Where a situation allows, case studies can also be presented to the trainees to widen their understanding of the real life specific problem/situation and to explore the solutions.

In simple terms, the case study method of teaching uses a real life case example/a typical case to demonstrate a phenomenon in action and explain theoretical as well as practical aspects of the knowledge related to the same. It is an effective way to help the trainees comprehend in depth both the theoretical and practical aspects of the complex phenomenon in depth with ease. Case teaching can also stimulate the trainees to participate in discussions and thereby boost their confidence. It also makes class room atmosphere interesting thus maintaining the trainee interest in training till the end of the course.

Depending on suitability to the trade, the weekly lesson plan in this document may suggest case studies to be presented to the trainees. The trainer may adopt a power point presentation or video format for such case studies whichever is deemed suitable but it's important that only those cases are selected that are relevant and of a learning value.

The Trainees should be required and supervised to carefully analyze the cases.

For the purpose they must be encouraged to inquire and collect specific information / data, actively participate in the discussions and intended solutions of the problem / situation.

Case studies can be implemented in the following ways:-

- i. A good quality trade specific documentary (At least 2-3 documentaries must be arranged by the training institute)
- ii. Health & Safety case studies (2 cases regarding

	<p>safety and industrial accidents must be arranged by the training institute)</p> <p>Field visits (At least one visit to a trade specific major industry/site must be arranged by the training institute)</p>
Learning Outcome of the Course	<p>By the end of the course the trainees will be able to have following competencies and skills.</p> <ul style="list-style-type: none"> • Understanding of the basic safety measure while working in machine shop • Understanding and performing preventive maintenance • Understanding and performing different operation (Facing, Turning, Threading, Drilling and boring) on CNC Turning Center • Understanding and performing different operation on Vertical machining center • Understanding and designing different part on CAD/CAM software • Understanding and performing different operations on CNC wire cut • Understanding and performing different operations on CNC EDM
Course Execution Plan	Total Duration of Course: 6 Months (26 Weeks)
	Class Hours: 4 Hours per day (06 Days per week)
	Theory: 20% Practical: 80%
	Weekly Hours: 24 Hours Per week
	Total Contact Hours: 600 Hours

Companies Offering Jobs in the respective trade	Atlas Honda, Honda Car, Indus motor, PAC Kamra, Navy, Air force, Auto parts manufacturer, Engineering components manufacturer, Dies and Mold manufacturer, Abroad (Gulf Countries, Malaysia, Indonesia, Japan, Korea)
Job Opportunities	The demand for the CNC operator and designer is increasing throughout the world. According to Zion Market research the market of the CNC machine will reach to USD 100.9 Billion worldwide. According to the GIZ 2016-17 report the demand for the skilled workforce is increasing over 50,000 in next 3 to 5 years in Light Engineering sector. The major skills needed by local industry includes, Tool and die Mold operator, CNC Operator and designer , Rubber and plastic dies and mold operator. According to the GIZ report Pakistan is currently having a gap of 21 % skilled labor in manufacturing sector.
No of Students	25
Learning Place	Classroom / Lab / Industry

WEEKLY SCHEDULE OF TRAINING

Scheduled Week	Module Title	Learning Units	Remarks
Week 1	Introduction	<ul style="list-style-type: none"> • Motivational Lecture (<i>For further detail please see Page No: 4</i>) • Application of the course • Job market overview • Institute/Work ethics (<i>For further detail please see Annexure-II at the end</i>) • Health & Safety • CNC Machine • Machine shop practices • Machine Shop safety • Safety Check List • Success story(<i>For further detail please see Page No: 5 and Annexure-III at the end</i>) 	
Week 2	Measurement and drawing	<ul style="list-style-type: none"> • Measuring tools application • Preventive Maintenance checklist • Basic understanding of drawings • Tolerance and Types of Tolerance • Success story (<i>For further detail please see Page No: 5 and Annexure-III at the end</i>) 	
Week 3	Coordinates system and geometry/algebra	<ul style="list-style-type: none"> • Motivational Lecture (<i>For further detail please see Page No: 4</i>) • Cartesian and Polar Coordinate System. • absolute coordinate system • Relative coordinates system • Basic geometry 	
Week 4	Machine preparation and operating	<ul style="list-style-type: none"> • Switching on/off of CNC T.C, • Machine home position, • spindle rotation, • Jaw clamping and unclamping • Case Study-1 (Health & Safety) (<i>For further detail please see Page No: 6</i>) 	Monthly Test – 1

Week 5	Operating CNC Machine	<ul style="list-style-type: none"> • Motivational Lecture (<i>For further detail please see Page No: 4</i>) • Work piece offset, • Inserting G and M codes in Machine panel. • Jog Modes 	
Week 6	CNC programs for Turning operations	<ul style="list-style-type: none"> • Straight turning, • Facing • Step turning • G71 cycle • Success story (<i>For further detail please see Page No: 5 and Annexure-III at the end</i>) 	Task – 1 <u>(Annex-1)</u>
Week 7	CNC programs for turning operations using G71 type 2 cycle	<ul style="list-style-type: none"> • Arc or radius (G02, G03) cutting • G71 type 2 programming • Chamfering and Fillet operation • Case Study-2 (Health & Safety)(<i>For further detail please see Page No: 6</i>) 	Task – 2 <u>(Annex-1)</u>
Week 8	CNC programs for turning operations using G71 type 2 cycle	<ul style="list-style-type: none"> • Motivational Lecture (<i>For further detail please see Page No: 4</i>) • Threading (G76), • drilling (G74), • boring operation on CNC T.C 	<ul style="list-style-type: none"> • Task – 3 <u>(Annex-1)</u> • Monthly Test – 2

Week 9	Introduction to CAD/Cam, Designing 2D Drawing in Power Shape	<ul style="list-style-type: none"> • Installation of power shape and power mill • Introduction to CAD CAM • Understanding and performing basic commands of CAD Software • Lines Command • Circle Command • Rectangle Command • Trimming command • Arc command, • polygon command • Success story (<i>For further detail please see Page No: 5 and Annexure-III at the end</i>) 	
Week 10	Designing 2D Drawings Using Different Commands in power Shape	<ul style="list-style-type: none"> • Motivational Lecture (<i>For further detail please see Page No: 4</i>) • Chamfer Command • Fillet Command • Copy Command • Paste Command • mirror Command • Pattern Command • Offset Command • Rotate Command • Scaling commands. 	Task – 4 <i>(Annex-1)</i>
Week 11	Designing 3D Drawings Using Different Commands in power Shape	<ul style="list-style-type: none"> • Extrusion • Block • Sphere • Cone • Solid • Case Study-3(<i>For further detail please see Page No: 6</i>) 	Task – 5 <i>(Annex-1)</i>

Week 12	Designing 3D Drawings Using Different Commands in power Shape	<ul style="list-style-type: none"> • Motivational Lecture (<i>For further detail please see Page No: 4</i>) • solid rotation • drive curve • solid chamfer • Solid Fillet 	<ul style="list-style-type: none"> • Task – 6 (<u><i>Annex-1</i></u>) • Monthly Test – 3
Week 13	Overview of the previous weeks & Mid Term Examination		
Week 14	Designing 3D Drawings Using Different Commands in power Shape	<ul style="list-style-type: none"> • Primitives • surface extrusions • surface revolutions • Success story (<i>For further detail please see Page No: 5 and Annexure-III at the end</i>) 	<ul style="list-style-type: none"> • Task – 7 (<u><i>Annex-1</i></u>)
Week 15	<ul style="list-style-type: none"> • Introduction to Power mill. • Introduction to Vertical Machining Center (VMC) 	<ul style="list-style-type: none"> • Motivational Lecture (<i>For further detail please see Page No: 4</i>) • Importing of 3D Solid • Creating Block • movement of block on 3 Axis • scaling rotation • Creating Work plan • Parts of VMC • Turning ON/OFF VMC • Introduction to Control Panel 	
Week 16	Selecting Cutting Tool, setting up Cutting Parameters and Creating tool Path in Power Mill	<ul style="list-style-type: none"> • Tool selection • Editing Tool Parameters • Defining Cutting Conditions. • Defining Cutting Speed. • Selecting appropriate tool Path • Applying Tool path. • Case Study-4(<i>For further detail please see Page No: 6</i>) 	

<p>Week 17</p>	<p>Applying different Cutting strategies, Creating NC code and Saving NC Code</p> <p>+</p> <p>Job search</p>	<ul style="list-style-type: none"> • Introduction to Roughing Strategies • Introduction to finishing strategies • Applying appropriate strategies to the given model. • Creating NC Code for each strategy • Saving NC Code • Job market & job search • Job related skills • Interpersonal skills • Communication skills • Success story (<i>For further detail please see Page No: 5 and Annexure-III at the end</i>) 	<p>Monthly Test – 4</p>
<p>Week 18</p>	<p>Introduction to VMC and Work offset.</p> <p>CV Building</p>	<ul style="list-style-type: none"> • Motivational Lecture (<i>For further detail please see Page No: 4</i>) • Machine Referencing • Tool movement with Hand Wheel • Jog Mode • Clamping tool in VMC • Fixing Job in vice • Job Paralleling • Introduction to work offset • Work offset methods • Session on CV Building • How to make notable CV • Dos and Don'ts of CV making 	
<p>Week 19</p>	<p>Manual Programming</p>	<ul style="list-style-type: none"> • Introduction to G & M Codes • Program Structure. • G01, G00, G90, G70, G94, G95, S, N, F, M, T • Point to point movement • Cutting with Z-height • Programming on CNC simulator • Profile Milling • Introduction to G-02 & G03 • Case Study-5(<i>For further detail please see Page No: 6</i>) 	

Week 20	Performing Milling operations on VMC using VMC Control Panel (Programming)	<ul style="list-style-type: none"> • Creating NC Code as per drawing provided by instructor. • Run the NC code on simulator • Wring code in VMC/ importing code from media • Execute the Program and perform following operations. • Face Milling • Slot Milling • Profile Milling • Success story (<i>For further detail please see Page No: 5 and Annexure-III at the end</i>) 	Task – 8 <u>(Annex-1)</u>
Week 21	Practical Activity (CNC Turning)	<ul style="list-style-type: none"> • Motivational Lecture (<i>For further detail please see Page No: 4</i>) <p>Perform the Following Operations using codes G00, G01, G02, G03, G71 cycle, G74, G76</p> <ul style="list-style-type: none"> • Facing • Step Turning • Radius Cutting • Chamfering & Filleting Operation • Threading Operation • Drilling & Boring Operation 	Task – 9 <u>(Annex-1)</u>
Week 22	Practical Activity (Power Shape + Power Mill + VMC)	<ul style="list-style-type: none"> • Create a 3D part in Power Shape • Import the part in Power Mill • Create appropriate tool Paths • Generate NC Code • Import code to VMC • Perform the Machining operation accordingly on VMC • Case Study-6(<i>For further detail please see Page No: 6</i>) 	<ul style="list-style-type: none"> • Task – 10 <u>(Annex-1)</u> • Monthly Test – 5
Week 23	Introduction and practical on CNC EDM Designing and Operating	<ul style="list-style-type: none"> • Introduction of EDM. • Safety for EDM • Electrode alignment on EDM • Machine • Work piece alignment • Work piece offset through manual • Work piece offset through Edge finder 	

		<ul style="list-style-type: none"> • Success story (<i>For further detail please see Page No: 5 and Annexure-III at the end</i>) 	
Week 24	<p>Developing and conducting program on CNC EDM</p> <p>Business Development & entrepreneurship</p>	<ul style="list-style-type: none"> • Motivational Lecture (<i>For further detail please see Page No: 4</i>) • Developing program for EDM • Performing practical on EDM • Session on Self-Employment • How to start a Business • Requirements (Capital, Physical etc) • Benefits/Advantages of self-employment 	
Week 25	<p>Introduction and practical on CNC Wire Cut Designing and Operating</p> <p>Developing and conducting program on CNC Wire Cut</p>	<ul style="list-style-type: none"> • Setting of wire in wire cut machine • Alignment of work piece on wire cut machine • Setting of parameters in Wire cut machine • Developing program for different shapes. • Performing practical on wire cut machine • Line cutting • Square cutting • Rectangular cutting • Case Study-7(<i>For further detail please see Page No: 6</i>) 	
Week 26	Overseas Employment	<ul style="list-style-type: none"> • Session on General Overseas Employment opportunities. • Job search Avenues. • Visa Processes and other necessary requirements. • Immigration Information (Legal age requirements, Health Certificate, Police Clearance & Travel Insurance) 	Final Assessment

	Continued... Overseas Employment	<ul style="list-style-type: none">• Selection of two countries of destination (Gulf Countries, Malaysia, South Korea etc) focusing on:-<ol style="list-style-type: none">I. Trade specific Job Prospects and Earning levels in that country.II. Country Specific Labor laws, entry and exit requirements (Legal age requirements, Health Certificate, Police Clearance & Travel Insurance etc.).	
--	-------------------------------------	---	--

TASKS FOR ADVANCE CNC OPERATOR

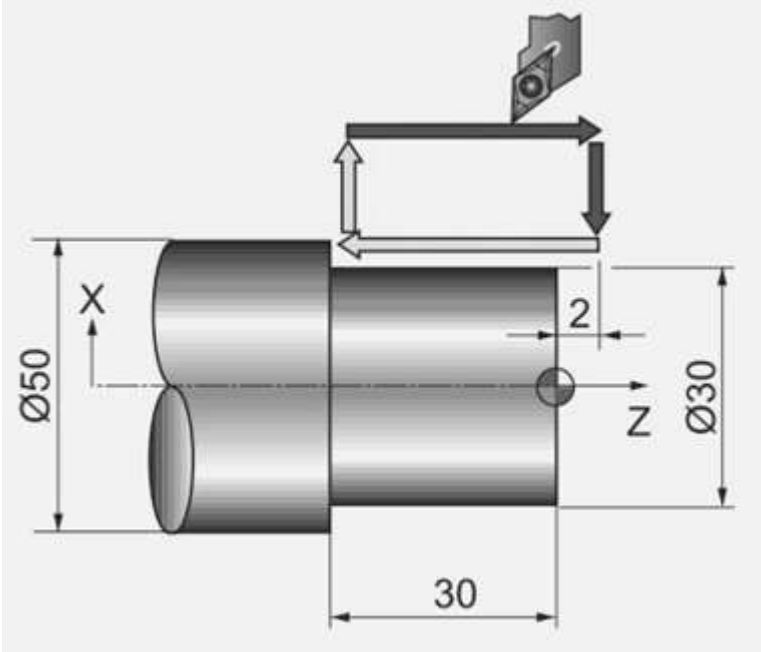
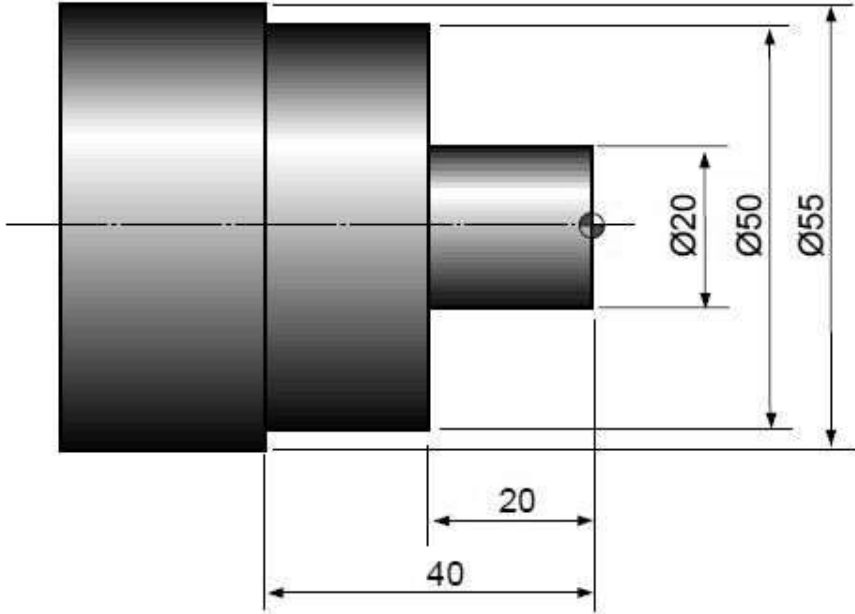
Task No.	(CNC Lath / Turner)
1	<p data-bbox="220 369 1382 405">Job. 1: Perform the Facing and Turning operations. All dimensions are in mm</p>  <p data-bbox="220 1140 1403 1176">Job. 2: Perform Step turning and Facing operations. All dimensions are in mm.</p> 

Task No.

(CNC Lath / Turner)

2 Job. 1: Perform the arc cutting and taper turning operations. Dimensions are in mm

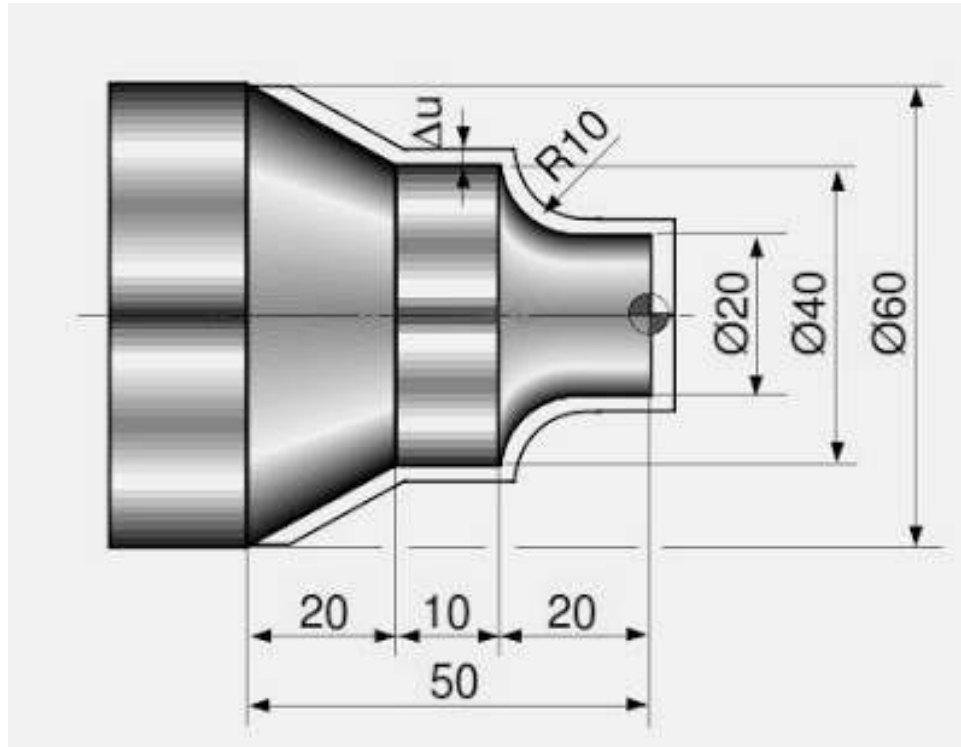

Job. 2:

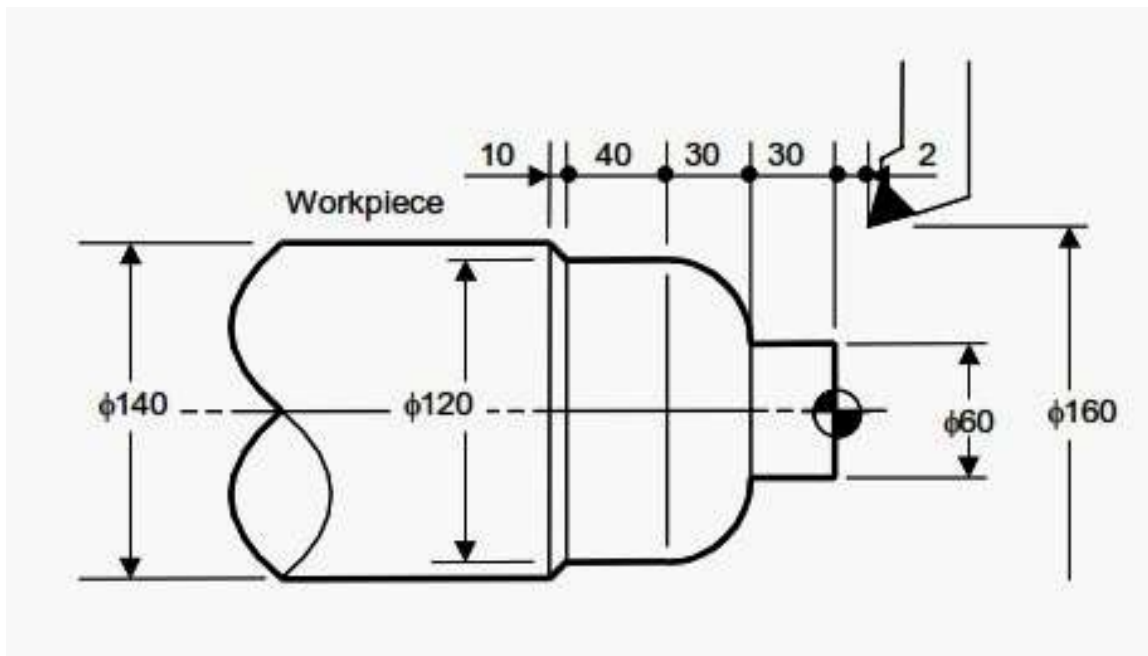

Task No.

(CNC Lath / Turner)

3

Job. 1 & Job. 2: Perform the threading operation according to given specifications. All dimensions are in mm.

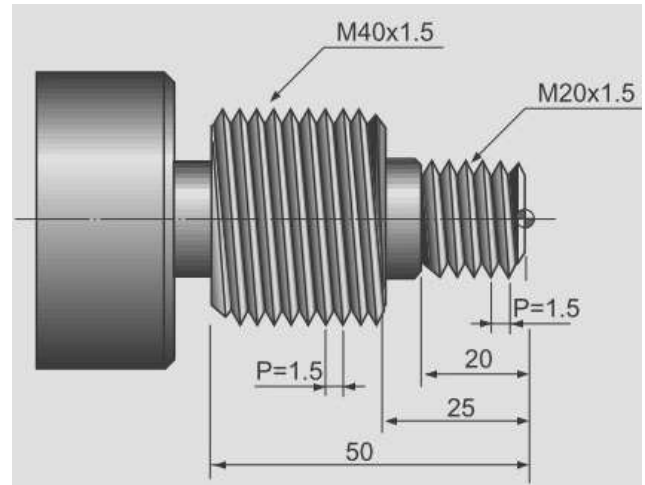
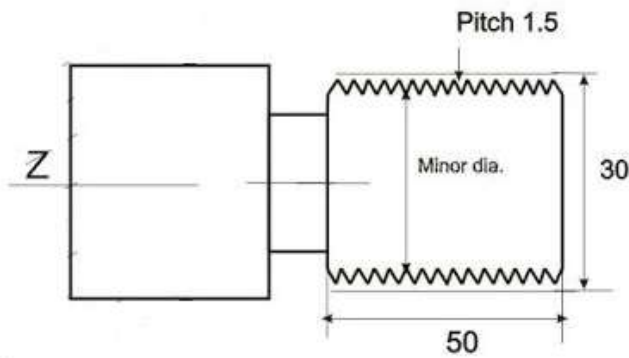

Job. 3: Perform the turning, step turning and boring operations.

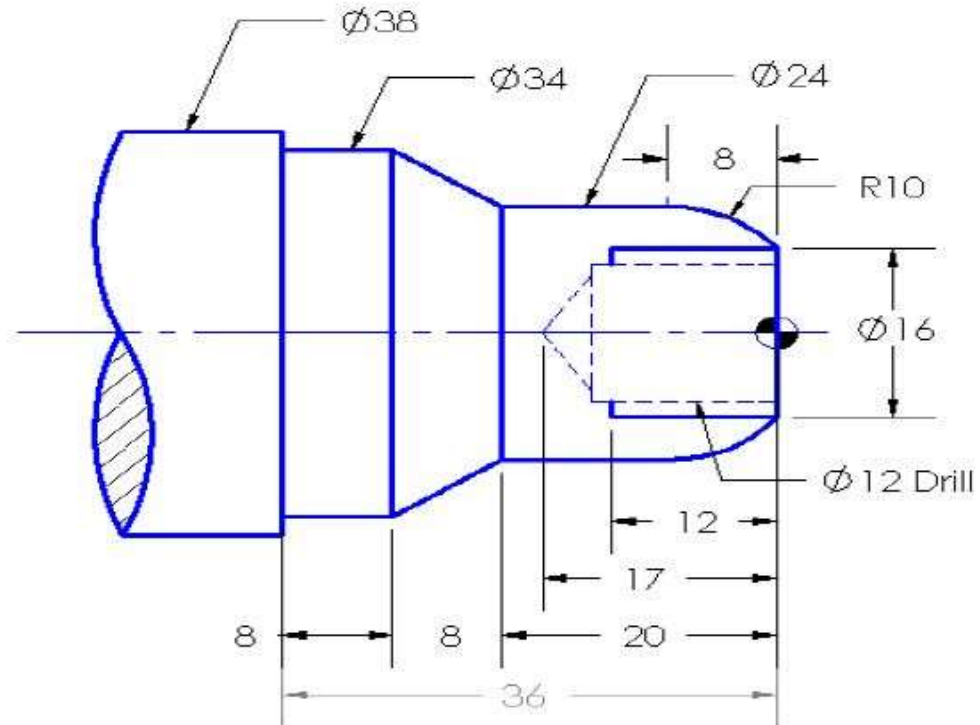

Task No.

(CNC Milling)

4 **Job. 1:** Any unit system may be used

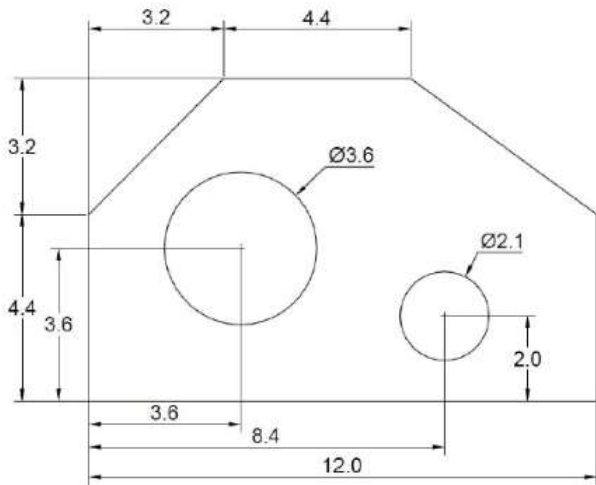

Job. 2:

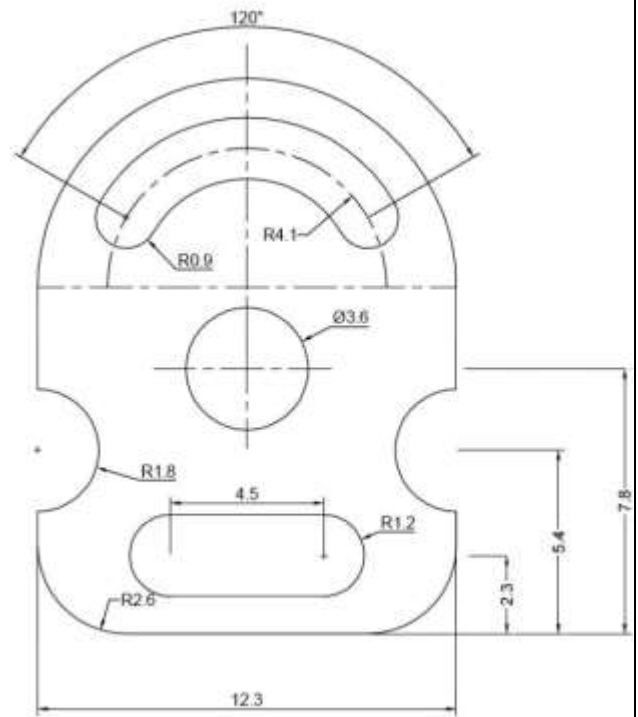

Job. 3: Apply Pattern command

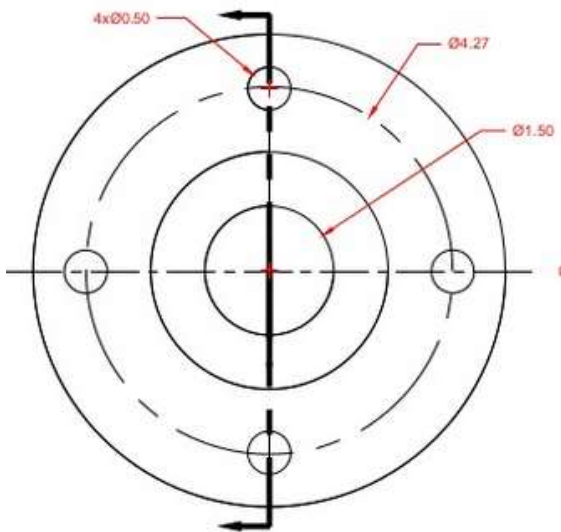

Task No.

(CNC Milling)

5

Draw the given shape in power shape all the dimensions are in mm.

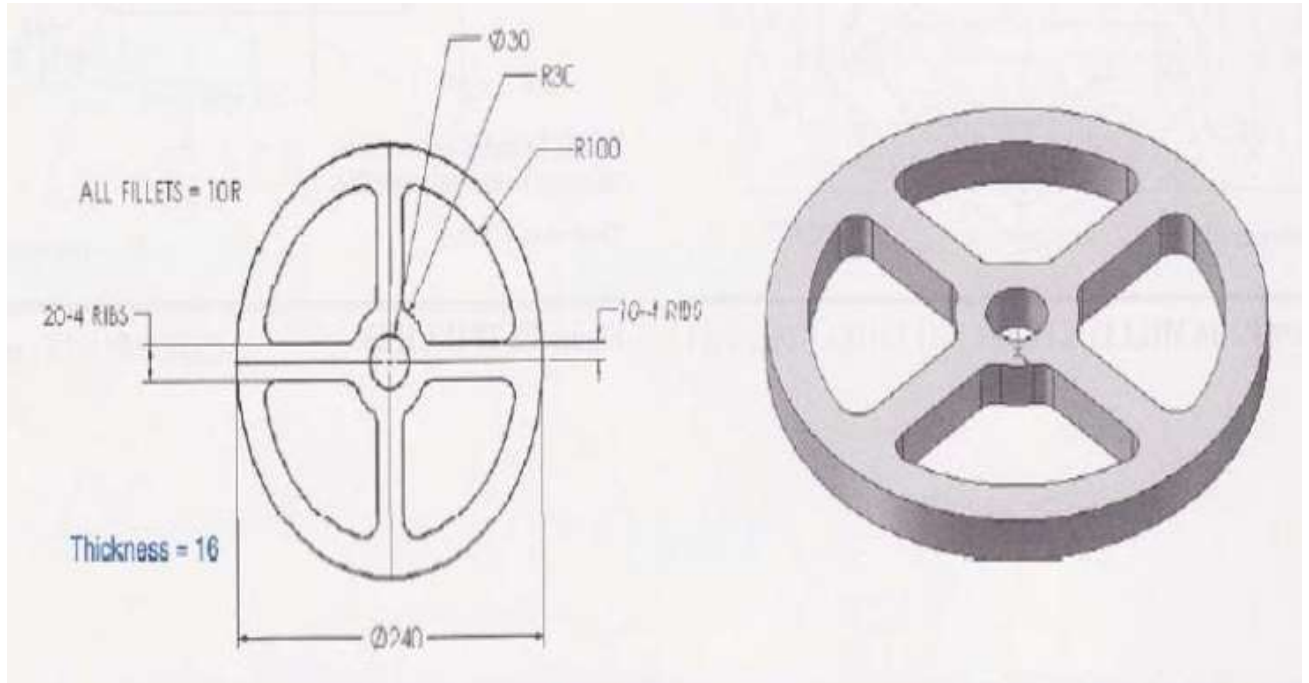

Fig. 1

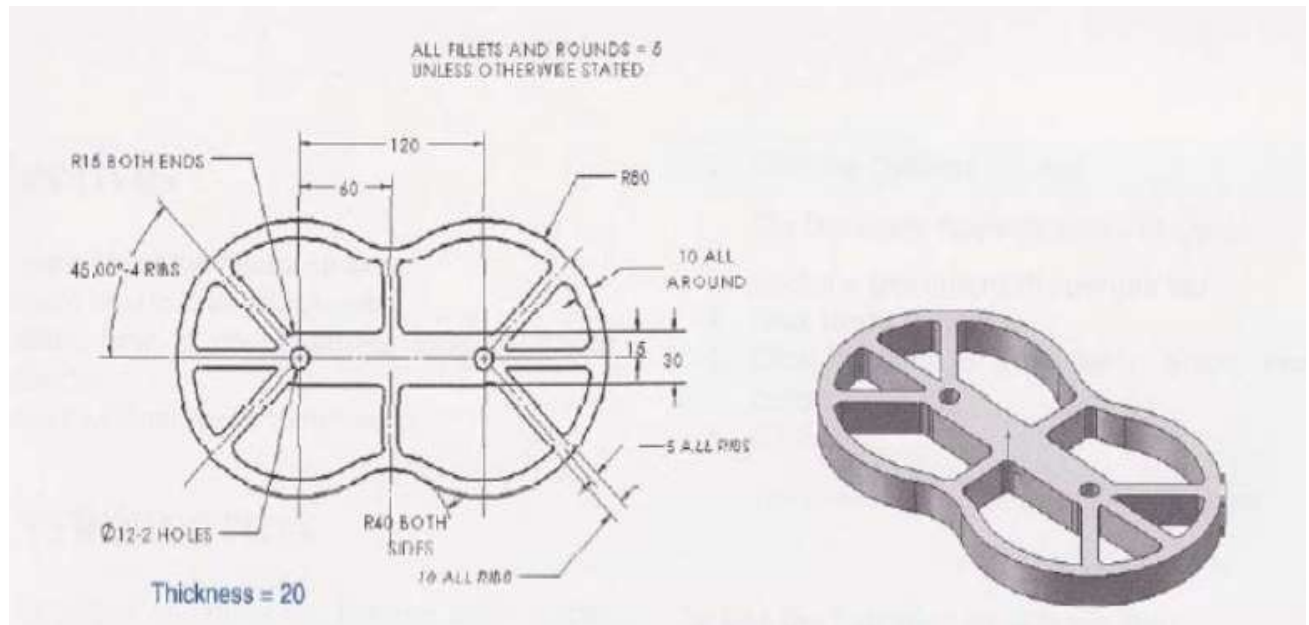

Fig.2

Task No.

(CNC Milling)

6 Create the following models using previously used 3D command (Extrude, Subtract/Remove material) also apply 3D fillet/ Solid Fillet and Solid chamfer command. All dimensions are in mm.

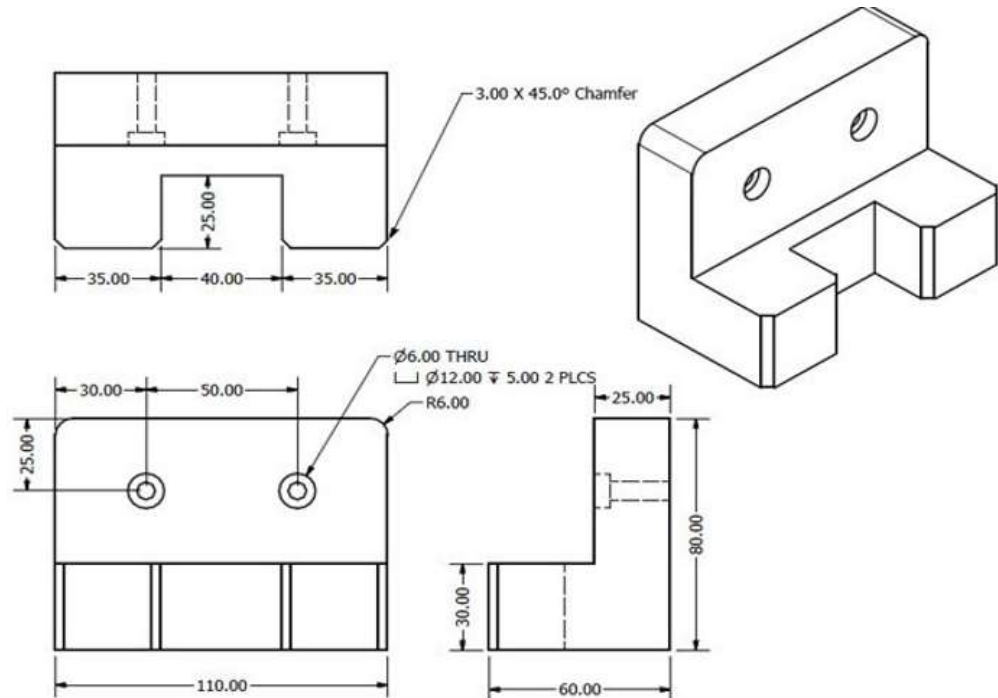

Fig. 1

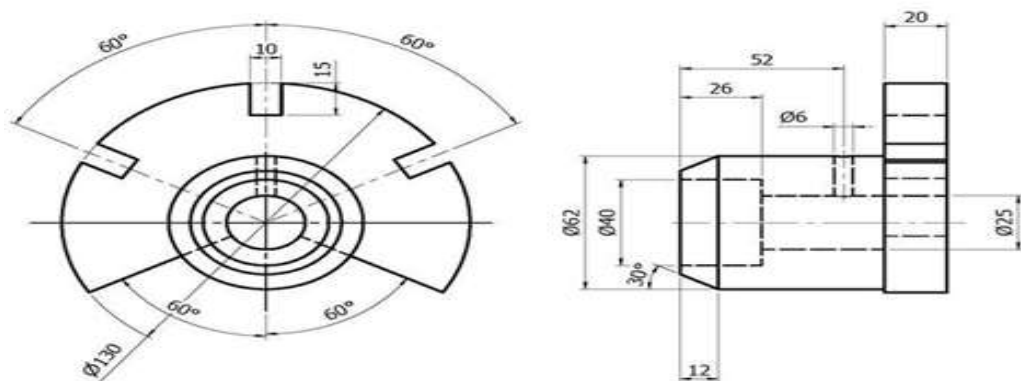
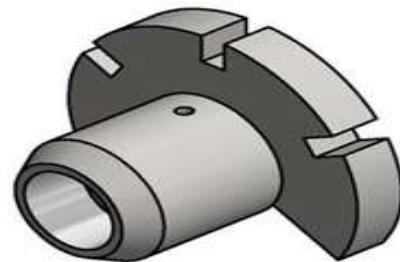

Fig. 2

Task No.

(CNC Milling)

7

Use the following commands to create the given model.

- Extrude surface
- Surface Revolution
- Fillet surface
- Fill surface

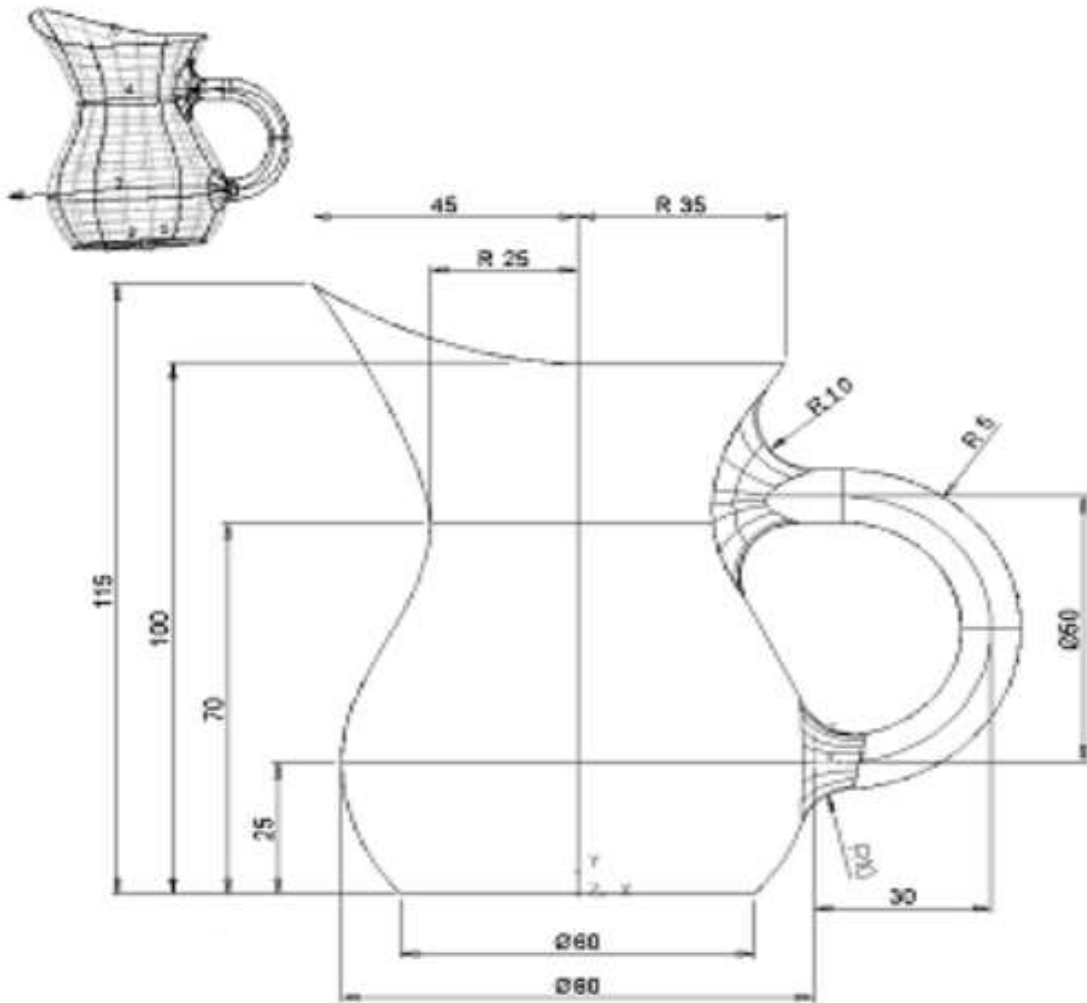

Task No.	(CNC Milling)
10	

Workplace/Institute Ethics Guide

Work ethic is a standard of conduct and values for job performance. The modern definition of what constitutes good work ethics often varies. Different businesses have different expectations. Work ethic is a belief that hard work and diligence have a moral benefit and an inherent ability, virtue or value to strengthen character and individual abilities. It is a set of values centered on importance of work and manifested by determination or desire to work hard.

The following ten work ethics are defined as essential for employee's success:

1. Attendance:

Be at work every day possible, plan your absences don't abuse leave time. Be punctual every day.

2. Character:

Honesty is the single most important factor having a direct bearing on the final success of an individual, corporation, or product. Complete assigned tasks correctly and promptly. Look to improve your skills.

3. Team Work:

The ability to get along with others including those you don't necessarily like. The ability to carry your own weight and help others who are struggling. Recognize when to speak up with an ideas and when to compromise by blend ideas together.

4. Appearance:

Dress for success, set your best foot forward, personal hygiene, good manner, remember that the first impression of who you are, can last a life time

5. Attitude:

Listen to suggestions and be positive, accept responsibility. If you make a mistake, admit it. Values workplace safety rules and precautions for personal and

co-worker safety. Avoids unnecessary risks. Willing to learn new processes, systems and procedures in light of changing responsibilities.

6. Productivity:

Do the work correctly, quality and timelines are prized. Get along with fellows, cooperation is the key to productivity. Help out whenever asked, do extra without being asked. Take pride in your work, do things the best you know how. Eagerly focuses energy on accomplishing tasks, also referred to as demonstrating ownership. Takes pride in work.

7. Organizational Skills:

Make an effort to improve, learn ways to better yourself. Time management; utilize time and resources to get the most out of both. Takes an appropriate approach to social interactions at work. Maintains focus on work responsibilities.

8. Communication:

Written communication, being able to correctly write reports and memos.

Verbal communications, being able to communicate one on one or to a group.

9. Cooperation:

Follow institute rules and regulations, learn and follow expectations. Get along with fellows, cooperation is the key to productivity. Able to welcome and adapt to changing workplace situations and the application of new or different skills.

10. Respect:

Work hard, work to the best of your ability. Carry out orders, do what's asked the first time. Show respect, accept and acknowledge an individual's talents and knowledge. Respects diversity in the workplace, including showing due respect for different perspectives, opinions and suggestions.

Annexure-III

Suggestive Format And Sequence Order Of Success Story

S. No	Key Information	Detail/Description
1.	Self & Family background	<ul style="list-style-type: none">• Self-introduction• Family background and socio economic status,• Education level and activities involved in• Financial hardships etc
2.	How he came on board NAVTTC Training/ or got trained through any other source	<ul style="list-style-type: none">• Information about course, apply and selection• Course duration, trade selection• Attendance, active participation, monthly tests, interest in lab work
3.	Post training activities	<ul style="list-style-type: none">• How job / business (self-employment) was set up• How capital was managed (loan (if any) etc).• Detail of work to share i.e. where is job or business being done; how many people employed (in case of self-employment/ business)• Monthly income or earnings and support to family• Earning a happy life than before
4.	Message to others (under training)	<ul style="list-style-type: none">• Take the training opportunity seriously• Impose self-discipline and ensure regularity• Make Hard work pays in the end so be always ready for the same.

Note: Success story is a source of motivation for the trainees and can be presented in a number of ways/forms in a NAVTTC skill development course as under: -

1. To call a passed out successful person of institute. He/she will narrate his/her success story to the trainees in his/her own words and meet trainees as well.
2. To see and listen to a recorded video/clip (5 to 7 minutes) showing a successful person Audio video recording that has to cover the above mentioned points.
3. The teacher displays the picture of a successful trainee (name, trade, institute, organization, job, earning per month etc) and narrates his/her story in teacher's own motivational words.